

Technical Specifications

- Capacity: From 500 kg to 100 tons
- Travel: 500 to 4000 mm
- Closed Height: 180 - 800 mm
- Length: 900 - 6000 mm
- Width: 650 - 3000 mm
- CE-Marked and comply with European Norms and Standards
- 2 Safety lock for maintenance
- Safety trip bar in aluminum
- Available in Ral Colors
- Large in-house lift table stock for immediate delivery



NOTE: ALL DETAILS CAN BE CUSTOMIZED FOR YOUR NEEDS

OndLift is biggest manufacturer company in Lifting Tables sector in Turkey and exporting 32 countries.

OndLift' s Lift Tables series, designed for high lifting capacities and performance of applications.

OndLift' s Lift Tables series can be the manufacturing with different kind of options, such as mobile base, loading flaps, guard rails, rollers. (for detailed information, please check Lift Table Accessories Datasheet).

OndLift' s Lift Table series, have a vital role to create ergonomic and safe working conditions. Can be the best selection of challenging situations, high lifting capacities, intense pace of work.

For more information www.ondlift.com



Art No	Model	Capacity kg	Platform Dimension LxW mm x mm	Lift Stroke H mm	Closed Height C mm	Lift Time sec	Motor kW	Weight kg
55.05.001	ESP.3/05-24-1	500	1350 x 1000	2400	530	32	1,5	550
55.05.002	ESP.3/05-24-2	500	1500 x 1000	2400	530	32	1,5	650
55.05.003	ESP.3/05-35	500	1800 x 1000	3500	530	45	2,2	1100
55.05.004	ESP.3/05-43	500	2250 x 1200	4300	530	55	2,2	1600
55.10.100	ESP.3/10-24-1	1000	1350 x 1000	2400	550	38	2,2	650
55.10.101	ESP.3/10-24-2	1000	1500 x 1000	2400	550	38	2,2	750
55.10.102	ESP.3/10-35	1000	1800 x 1000	3500	550	45	2,2	1300
55.10.103	ESP.3/10-43	1000	2250 x 1200	4300	650	60	2,2	1900
55.15.200	ESP.3/15-24	1500	1500 x 1000	2400	550	40	2,2	850
55.15.201	ESP.3/15-25	1500	1800 x 1000	2500	550	45	2,2	1500
55.15.202	ESP.3/15-43	1500	2250 x 1200	4300	650	60	3	2200
55.20.300	ESP.3/20-24	2000	1500 x 1000	2400	550	40	2,2	1000
55.20.301	ESP.3/20-35	2000	1800 x 1000	3500	650	45	2,2	1650
55.20.302	ESP.3/20-43	2000	2250 x 1500	4300	750	60	3	3000
55.20.303	ESP.3/20-58	2000	3000 x 2000	5800	750	75	3	4000
55.30.400	ESP.3/30-40	3000	2250 x 1500	4000	800	70	4	3500
55.30.401	ESP.3/30-55	3000	3000 x 2000	5500	800	80	4	4750
55.40.500	ESP.3/40-40	4000	2250 x 1500	4000	800	75	4	3750
55.40.501	ESP.3/40-55	4000	3000 x 2000	5500	900	90	4	5250

* External power pack

Technical Drawing

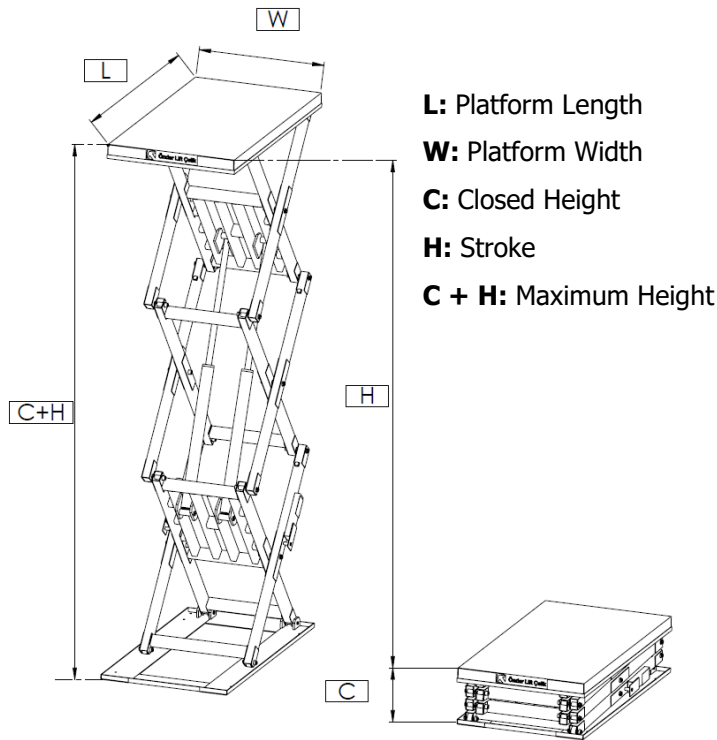

Load Factors Accordance with EN1570-1

Maximum load refers to the load being uniformly distributed over the entire platform area in accordance with EN 1570 the basic requirements are;

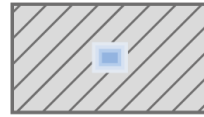

100 % of maximum load uniformly distributed over the entire platform.

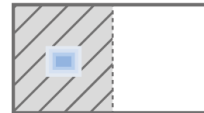

50 % of load weight uniformly distributed over half of the platform area lengthwise.



33 % of load weight uniformly distributed over half of the platform area sideways.

Standard Pit Details

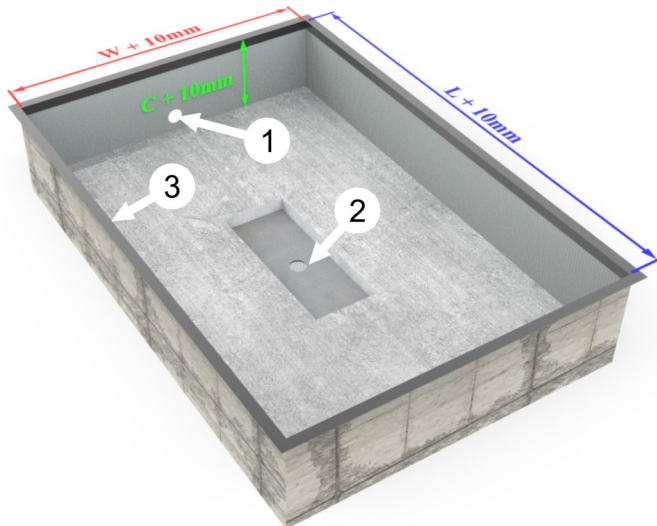

When a lifting table is installed in a pit, the pit should be constructed according to the illustration on the left.

W = Width of the platform
 L = Length of the platform
 H = Lowest height of the lift table

The pit's ballast material must at least meet the concrete classification C12/15.

The hydraulic power pack for lifting tables in an outdoor environment should, where possible, be externally located in a covered or indoor environment.

- 1- Pipe for incoming cables, 100 mm in diameter. The fixed side of the lift table.
- 2- Drainage holes where required. This is centre of the pit should be 80 mm.
- 3- L-shaped profile 100 x 100 mm to reinforce the pit edges.

ONDLIFT Mak. San. Tic. Ltd. Şti

Factory: Organize Sanayi Bolgesi 2004 Cad. No: 4
 Turgutlu/Manisa/TURKEY

Showroom: İmes San. Sit. C.302 Sk. No:13
 Y.Dudullu/Umraniye/Istanbul/TURKEY

Tel: 0090 236 332 5050

ondlift@ondlift.com

Product specifications are subject to change without any notice or obligation. The photographs and/or drawing in this documents are for illustrative purpose only. All productions of OndLift, manufacturing for CE standards.

Turkey
 Discover the potential

Onder Lift Celik



43rd Years Anniversary

Your warehouse partner

Onder Group Company